

Ball Check Valve

NPT

Model 508/50

FLOMATIC®
Flomatic Corporation

Sizes 3" / 80mm

Materials

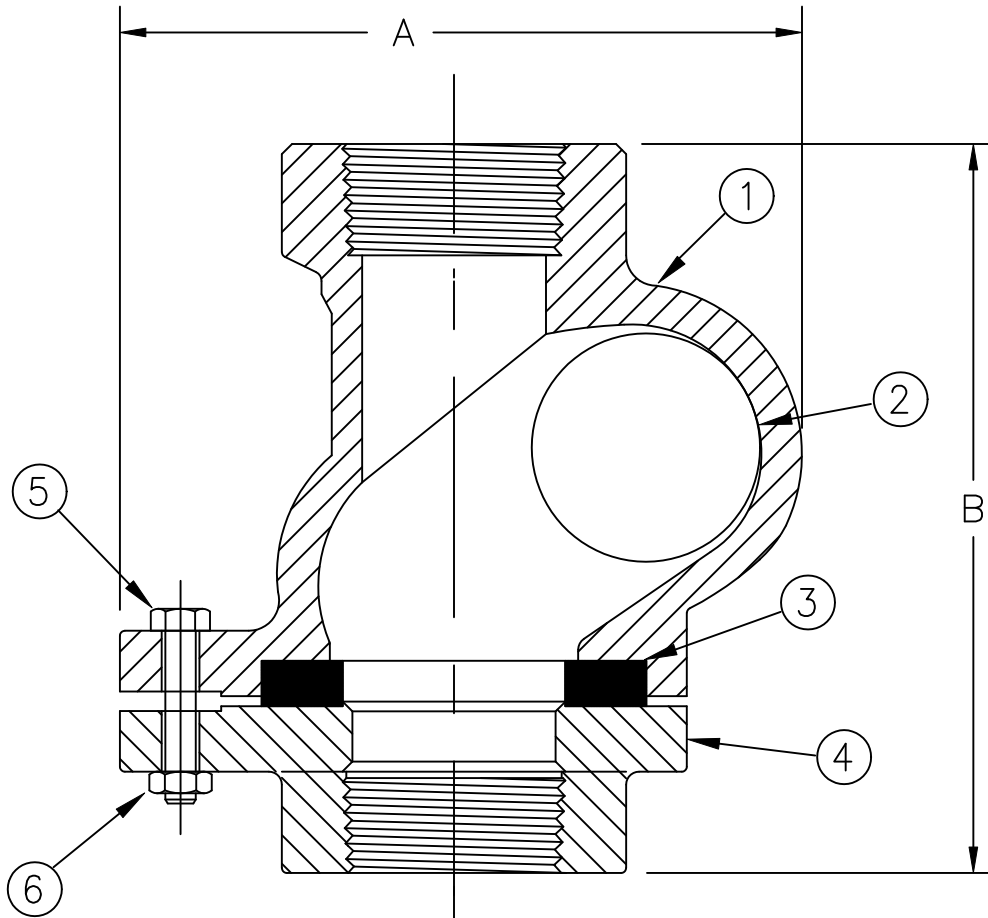
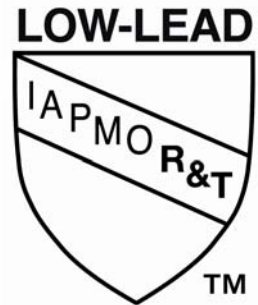

Item #	Qty	Description	Material	ASTM
1	1	Body (Epoxy Coated)	Cast Iron	A-48
2	1	Ball (Sinking)*	Phenolic	-----
3	1	Seal	Polyurethane	-----
4	1	Flange (Epoxy Coated)	Cast Iron	A-48
5	4	Bolt	Stainless Steel	304
6	4	Nut	Stainless Steel	304

*Optional floating ball available add "FB" to part number
 Max Temp 180°F (82°C)
 Max Inlet Pressure 150 psi (10 bar)

Dimensions

Size		Part #	A		B		Weight	
Inch	mm		Inch	mm	Inch	mm	lbs	kg
3	80	2044	8-9/16	218	9-19/32	244	30	14

Flomatic Corporation can accept no responsibility for possible errors in catalogues, brochures and other printed material. Flomatic Corporation reserves the right to alter its products without notices. This also applies to product already agreed. All trademarks in this material are property of the respective companies. All right reserved. ©2011 Flomatic Corporation. The drawings & information on this drawing sheet are the sole & exclusive property of Flomatic Corporation. Any reproduction, distribution, display or use of these drawings or information in whole or in part without written authorization of Flomatic Corporation is strictly prohibited.