

Ball Check Valve

Sizes 5" & 14" / 125 mm & 350 mm

Model 408 **FLOMATIC**[®]
Flomatic Corporation

Materials

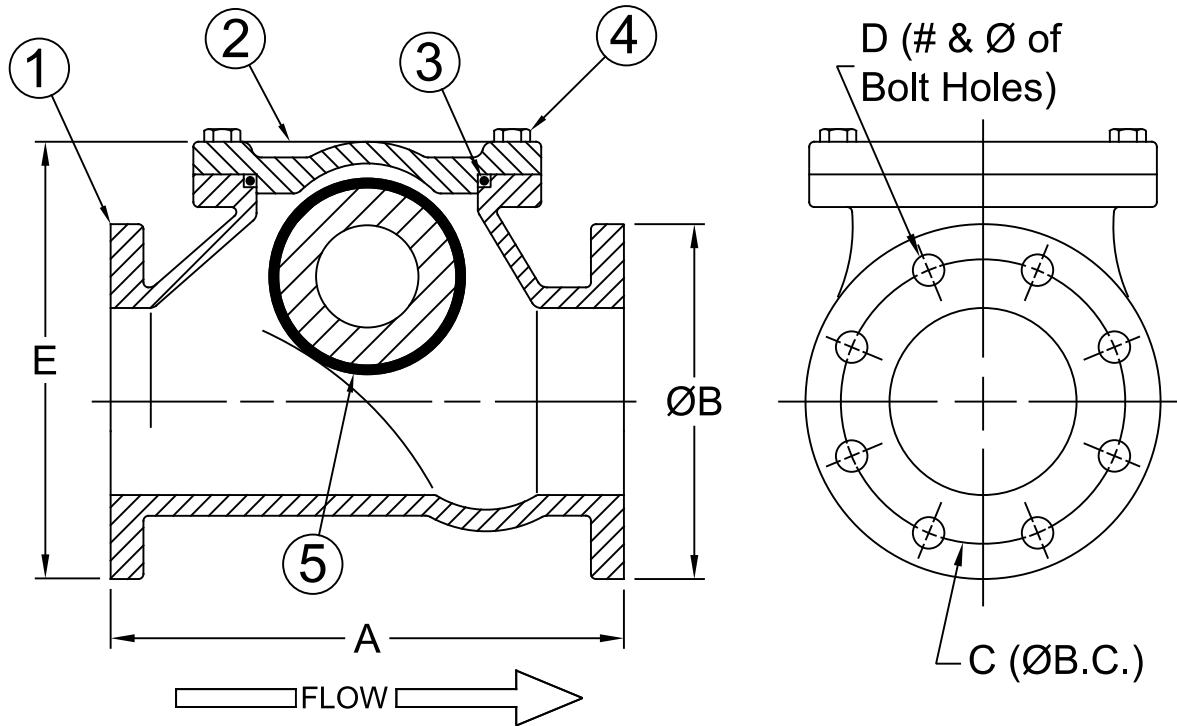
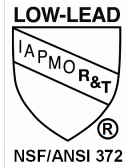

Max Temp 180°F (82°C)
Max Inlet Pressure 150 psi (10 bar)

Item #	Qty	Description	Material	ASTM
1	1	Body (Epoxy Coated)	Cast Iron	A48
2	1	Cover (Epoxy Coated)	Cast Iron	A48
3	1	O-Ring	Buna-N	-----
4	A/R	Bolt	Stainless Steel	18-8
5	1	Ball (Sinking)*	Buna-N/Metal Ball	-----

*Optional floating ball available add "FB" to part number

Dimensions (125# ANSI 16.1 Flanges)

Size		Part #	A		ØB		C		D		E		Weight	
inch	mm		inch	mm	inch	mm	inch	mm	inch	mm	inch	mm	lbs	kg
5	125	2143	13-25/32	350	10	254	8-1/2	216	(8) 7/8	22	13-1/8	333	85	39
14	350	2150	34-29/64	875	21	533	18-3/4	476	(12) 1-1/8	29	32-9/32	820	790	358

Flomatic Corporation can accept no responsibility for possible errors in catalogues, brochures and other printed material. Flomatic Corporation reserves the right to alter its products without notices. This also applies to product already agreed. All trademarks in this material are property of the respective companies. All rights reserved. ©2021 Flomatic Corporation. The drawings & information on this drawing sheet are the sole & exclusive property of Flomatic Corporation. Any reproduction, distribution, display or use of these drawings or information in whole or in part without written authorization of Flomatic Corporation is strictly prohibited. www.flomatic.com