

Ball Check Valve

Model 208VB



Flomatic Corporation

Sizes 2" / 50 mm

Materials (with Air Bleeder)

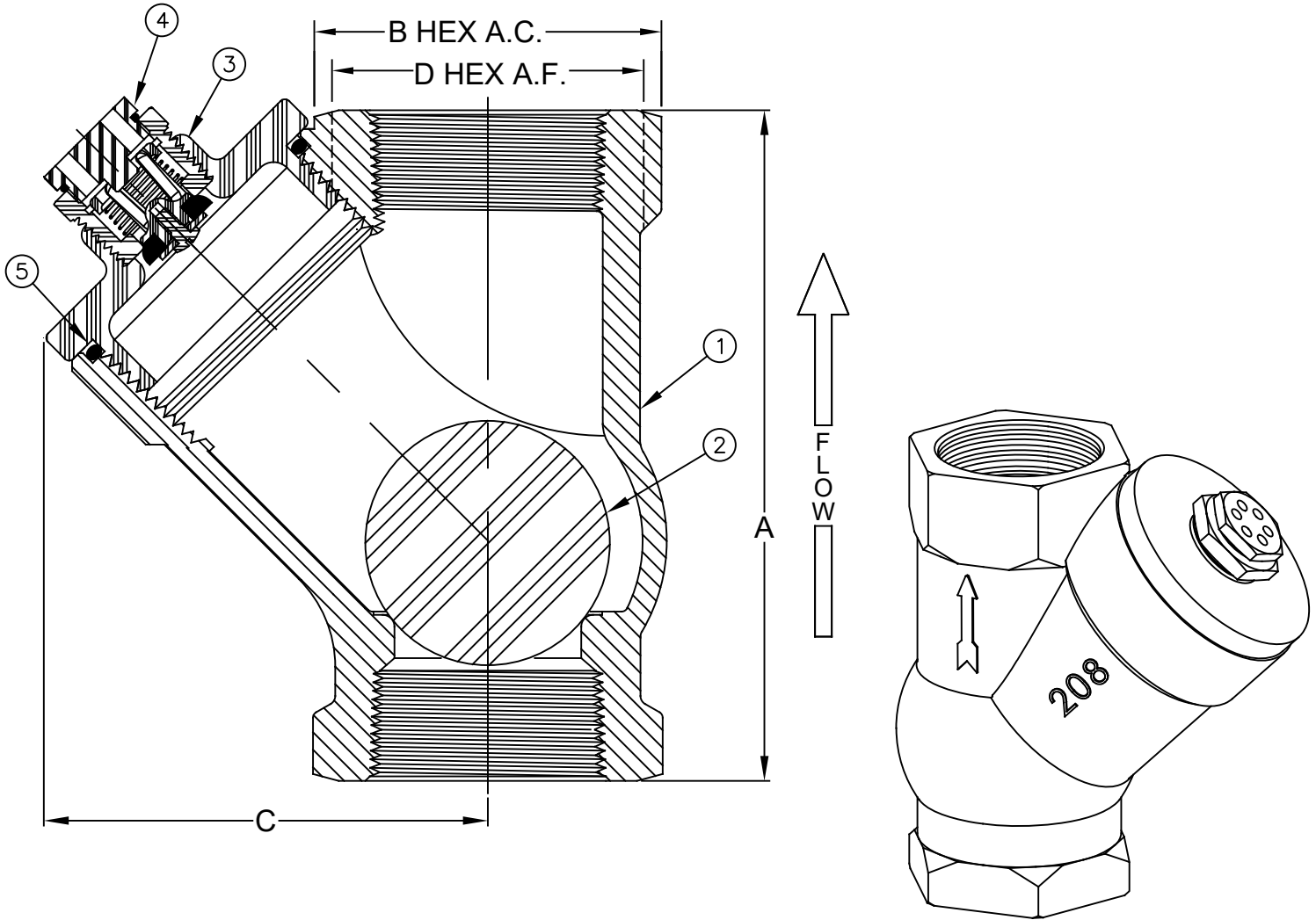
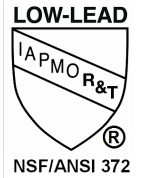

Max Temp 180°F (82°C)
Max Inlet Pressure 150 psi (10 bar)

Item #	Qty	Description	Material	Standard
1	1	Body (Epoxy Coated)	Cast Iron Class B	ASTM A126
2	1	Ball (Sinking)	Buna-N	-----
3	1	Cover	PVC	-----
4	1	Model 77	PVC	-----
5	1	O-Ring	Buna-N	-----

Dimensions (FNPT X FNPT)

ANSI B1.20.1

Size		Part #	A		B		C		D		Weight	
inch	mm		inch	mm	inch	mm	inch	mm	inch	mm	lbs	kg
2	50	2142-1	6.75	171	3.50	89	4.19	106	3	77	9	4

Flomatic Corporation can accept no responsibility for possible errors in catalogues, brochures and other printed material. Flomatic Corporation reserves the right to alter its products without notices. This also applies to product already agreed. All trademarks in this material are property of the respective companies. All rights reserved. ©2024 Flomatic Corporation. The drawings & information on this drawing sheet are the sole & exclusive property of Flomatic Corporation. Any reproduction, distribution, display or use of these drawings or information in whole or in part without written authorization of Flomatic Corporation is strictly prohibited. www.flomatic.com



February 17, 1998
Dwg No:S2142-1 Rev: K (6/24)

FLOMATIC CORPORATION
GLENS FALLS, N.Y. 12801
PHONE (518) 761-9797
FAX (518) 761-9798