

# Plastic Check Valve

# Model 901



Sizes 3/4" & 1" / 20mm & 25mm

## Materials

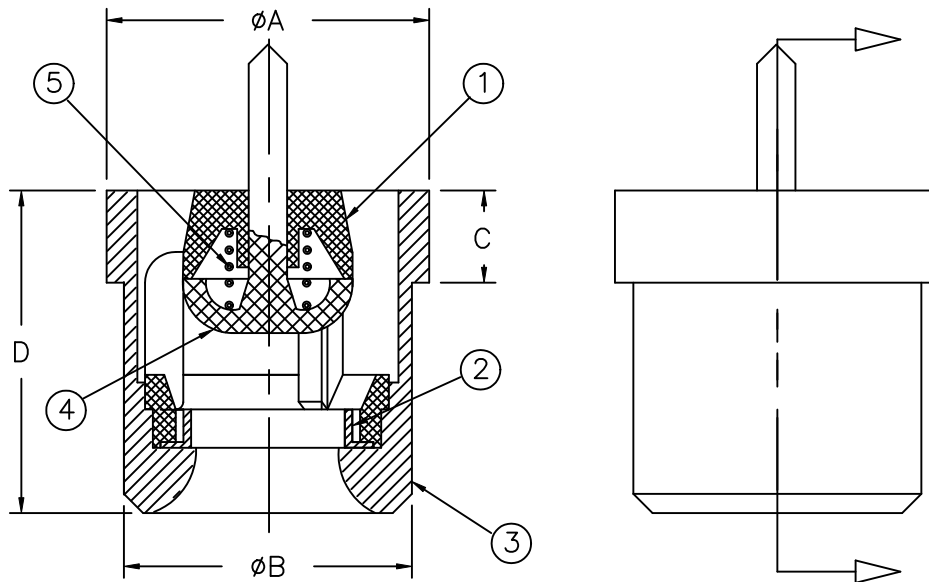

Max Temp 180°F (82°C)  
Max Inlet Pressure 150 psi (10 bar)

Item #	Qty	Description	Material	ASTM
1	1	Guide	Polyacetal	-----
2	1	Seal	Nitrile	-----
3	1	Body	Polyacetal	-----
4	1	Poppet	Polyacetal	-----
5	1	Spring	Stainless Steel	302

## Dimensions

Size		Part #	A		B		C		D		Weight	
Inch	mm		Inch	mm	Inch	mm	Inch	mm	Inch	mm	lbs	kg
3/4	20	2001	1	25	7/8	22	9/32	7	1	25	.022	.010
1	25	2030	1-1/4	32	1-1/8	29	5/16	8	1-1/2	38	.033	.015

Flomatic Corporation can accept no responsibility for possible errors in catalogues, brochures and other printed material. Flomatic Corporation reserves the right to alter its products without notices. This also applies to product already agreed. All trademarks in this material are property of the respective companies. All right reserved. ©2016 Flomatic Corporation. The drawings & information on this drawing sheet are the sole & exclusive property of Flomatic Corporation. Any reproduction, distribution, display or use of these drawings or information in whole or in part without written authorization of Flomatic Corporation is strictly prohibited.



July 3, 2008  
Dwg No: S901\_2 Rev C (4/16)

FLOMATIC CORPORATION  
GLENS FALLS, N.Y. 12801  
PHONE (518) 761-9797  
FAX (518) 761-9798