

Foot Valve

Model 190D



Flomatic Corporation

Sizes 1-1/2" & 2" / 40mm & 50mm



Materials

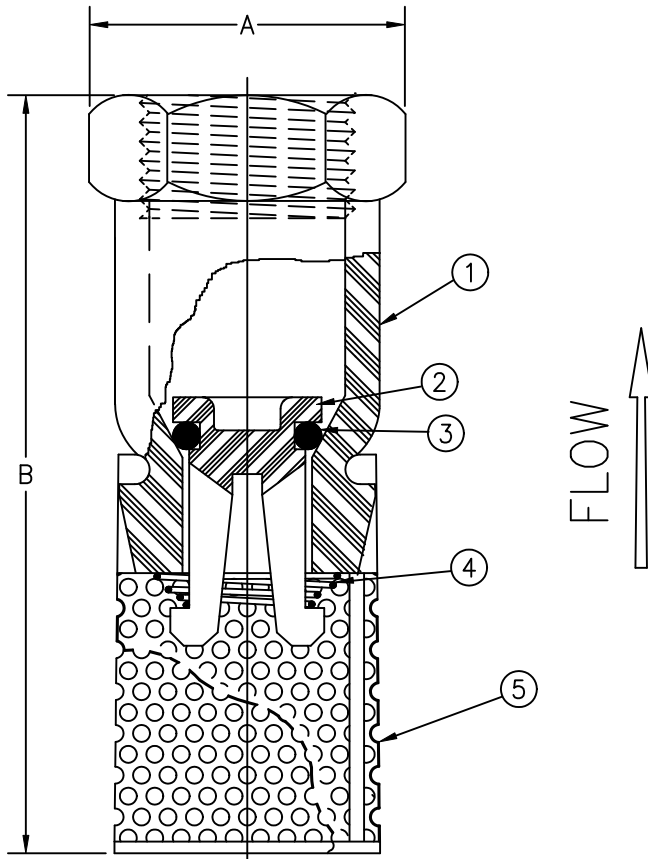

Open Area: 60%
 Max Temp 140°F (60°C)
 Max Pressure 150psi (10bar)

Item #	Qty	Description	Material	ASTM
1	1	Body	Polyacetal	-----
2	1	Poppet	Polyamid	-----
3	1	Seal	EPDM	-----
4	1	Spring	Stainless Steel	18-8
5	1	Strainer	Polyethylene	-----

Dimensions

Size		Part #	A		B		Weight	
inch	mm		inch	mm	inch	mm	lbs	kg
1-1/2	40	5724	2-13/64	56	5-53/64	148	3/8	.17
2	50	5725	2-19/32	66	7-5/64	180	13/32	.19

Flomatic Corporation can accept no responsibility for possible errors in catalogues, brochures and other printed material. Flomatic Corporation reserves the right to alter its products without notices. This also applies to product already agreed. All trademarks in this material are property of the respective companies. All right reserved. ©2011 Flomatic Corporation. The drawings & information on this drawing sheet are the sole & exclusive property of Flomatic Corporation. Any reproduction, distribution, display or use of these drawings or information in whole or in part without written authorization of Flomatic Corporation is strictly prohibited.



January 16, 1998
 Dwg No: S190D Rev C (2/14)

FLOMATIC CORPORATION
 GLENS FALLS, N.Y. 12801
 PHONE (518) 761-9797
 FAX (518) 761-9798