

Foot Valve

Model 357



Flomatic Corporation

Sizes 1-1/4" Thru 8" / 32mm Thru 200mm

Material

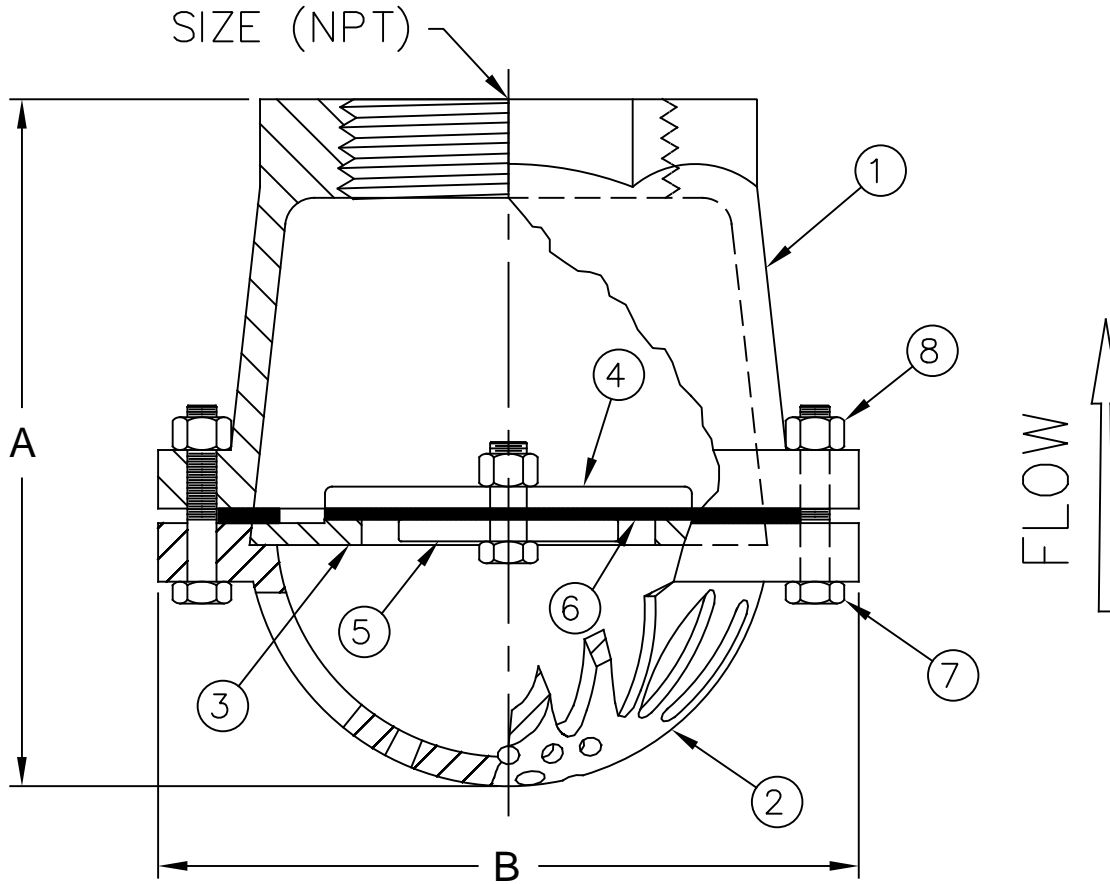

Max Temp 80°F (27°C)
Max Pressure 20psi (1.4bar)

Item #	Qty	Description	Material	ASTM	Item #	Qty	Description	Material	ASTM
1	1	Body	Cast Iron	A-48	5	1	Weight	Cast Iron	A-48
2	1	Strainer	Cast Iron	A-48	6	1	Seal	Leather	-----
3	1	Seat	Cast Iron	A-48	7	A/R	Hex Bolt	Zinc Plated	-----
4	1	Weight	Cast Iron	A-48	8	A/R	Hex Nut	Zinc Plated	-----

A/R=Amount Required

Dimensions

Size		Part #	A		B		Weight	
inch	mm		inch	mm	inch	mm	lbs	kg
1-1/4	32	4962	4-1/8	105	4-7/8	124	3	1.3
1-1/2	40	4963	4-1/8	105	4-7/8	124	3	1.3
2	50	4964	5-1/4	133	5-7/8	149	6	2.7
3	80	4966	7-1/8	181	7-1/2	191	13	5.9
4	100	4967	9	229	9	229	20	9.1
6	100	4969	12	305	11-3/8	289	45	20
8	100	4970	15-11/16	398	15-1/8	384	99	45

Flomatic Corporation can accept no responsibility for possible errors in catalogues, brochures and other printed material. Flomatic Corporation reserves the right to alter its products without notices. This also applies to product already agreed. All trademarks in this material are property of the respective companies. All rights reserved. ©2020 Flomatic Corporation. The drawings & information on this drawing sheet are the sole & exclusive property of Flomatic Corporation. Any reproduction, distribution, display or use of these drawings or information in whole or in part without written authorization of Flomatic Corporation is strictly prohibited. www.flomatic.com



August 12, 1994
Dwg No: S4964-70 Rev: G (2/20)

FLOMATIC CORPORATION
GLENS FALLS, N.Y. 12801
PHONE (518) 761-9797
FAX (518) 761-9798