

Foot Valve

Model 63VFD



Flomatic Corporation

Sizes 6" / 150mm

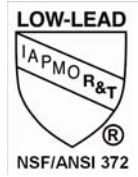

Material

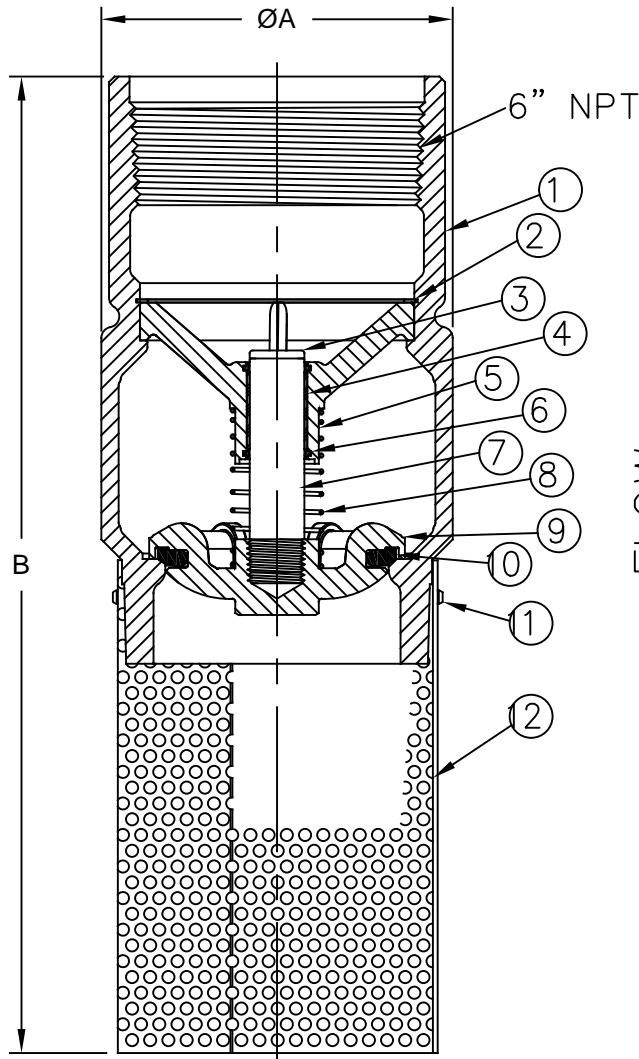

Max Temp 180°F (82°C)
Max Pressure 250psi (18bar)

Item #	Qty	Description	Material	ASTM	Item #	Qty	Description	Material	ASTM
1	1	Body	Ductile Iron	65-45-12	7	1	Stem	Stainless Steel	316
2	1	Retaining Ring	Stainless Steel	302	8	1	Spring	Stainless Steel	302
3	1	Stem Cap	Engineered Composite	-----	9	1	Poppet	Ductile Iron	65-45-12
4	1	Bushing	Engineered Composite	-----	10	1	Disc	Buna-n	-----
5	1	Stem Guide	Ductile Iron	65-45-12	11	3	Screw	Stainless Steel	304
6	2	Wipers	Engineered Composite	-----	12	1	Screen	Galvanized Steel	-----

Dimensions (FNPT)

Size		Part #	A		B		Weight	
inch	mm		inch	mm	inch	mm	lbs	kg
6	150	4789VFD	8	203	21.3	541	55	25

Flomatic Corporation can accept no responsibility for possible errors in catalogues, brochures and other printed material. Flomatic Corporation reserves the right to alter its products without notices. This also applies to product already agreed. All trademarks in this material are property of the respective companies. All right reserved. ©2019 Flomatic Corporation. The drawings & information on this drawing sheet are the sole & exclusive property of Flomatic Corporation. Any reproduction, distribution, display or use of these drawings or information in whole or in part without written authorization of Flomatic Corporation is strictly prohibited. www.flomatic.com



June 15, 1994
Dwg No: S4789 Rev: G (3/19)

FLOMATIC CORPORATION
GLENS FALLS, N.Y. 12801
PHONE (518) 761-9797
FAX (518) 761-9798