

Foot Valve

Model 812XTF



Flomatic Corporation

Sizes 3" & 4" / 75mm & 100mm



Material

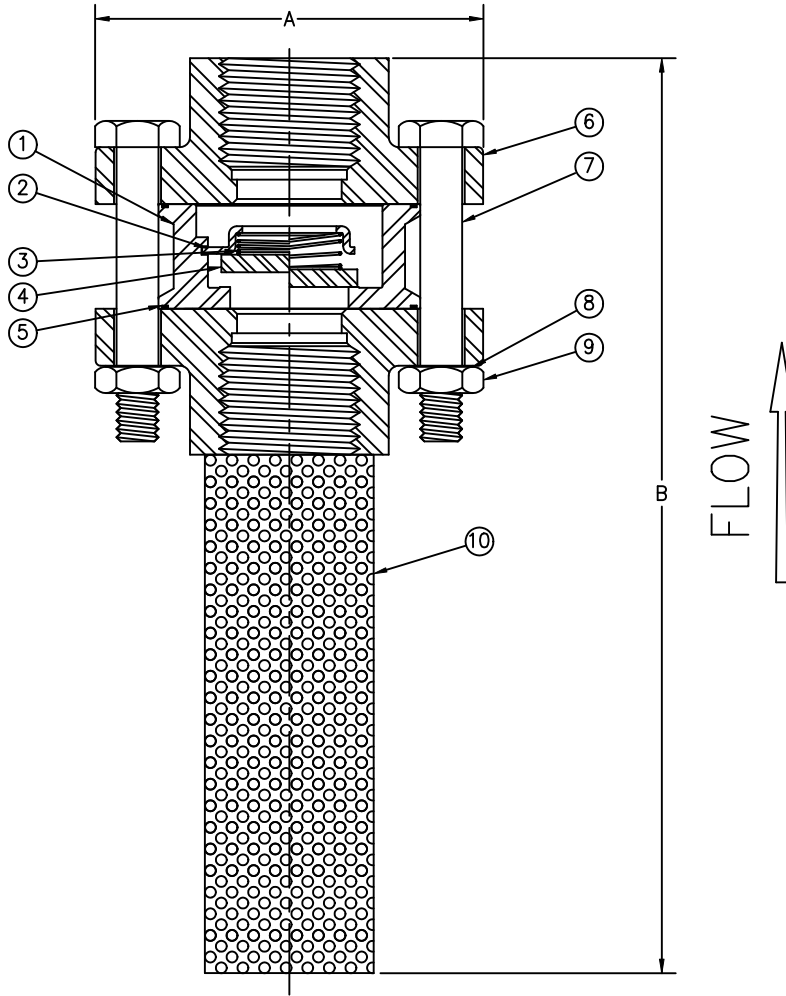

Open Area: 25-30%
 Max Temp 400°F (200°C)
 Max Pressure 300psi (21bar)

Item #	Qty	Description	Material	ASTM	Item #	Qty	Description	Material	ASTM
1	1	Body	Stainless Steel	316	6	2	Flange	Stainless Steel	316
2	1	Holder	Stainless Steel	316	7	A/R	Hex Head Bolt	Stainless Steel	316
3	1	Spring	Stainless Steel	316	8	A/R	Washer	Stainless Steel	316
4	1	Disc	Stainless Steel	316	9	1	Hex Head Nut	Stainless Steel	316
5	2	Seal	PTFE	—	10	1	Screen	Stainless Steel	316

A/R=Amount Required

Dimensions

Size		Part #	A		B (REF)		Weight	
Inch	mm		Inch	mm	Inch	mm	lbs	kg
3	75	2427XTF	7-3/4	197	12-1/4	311	25	11
4	100	2428XTF	8-13/16	224	16	406	39	18

Flomatic Corporation can accept no responsibility for possible errors in catalogues, brochures and other printed material. Flomatic Corporation reserves the right to alter its products without notices. This also applies to product already agreed. All trademarks in this material are property of the respective companies. All right reserved. ©2011 Flomatic Corporation. The drawings & information on this drawing sheet are the sole & exclusive property of Flomatic Corporation. Any reproduction, distribution, display or use of these drawings or information in whole or in part without written authorization of Flomatic Corporation is strictly prohibited.



August 28, 1996
 Dwg No: S812XTF2 Rev: E (7/13)

FLOMATIC CORPORATION
 GLENS FALLS, N.Y. 12801
 PHONE (518) 761-9797
 FAX (518) 761-9798