

# Foot Valve

# Model 812XTF



Fromatic Corporation

Sizes 6" Thru 8" / 150 mm & 200 mm

## Materials

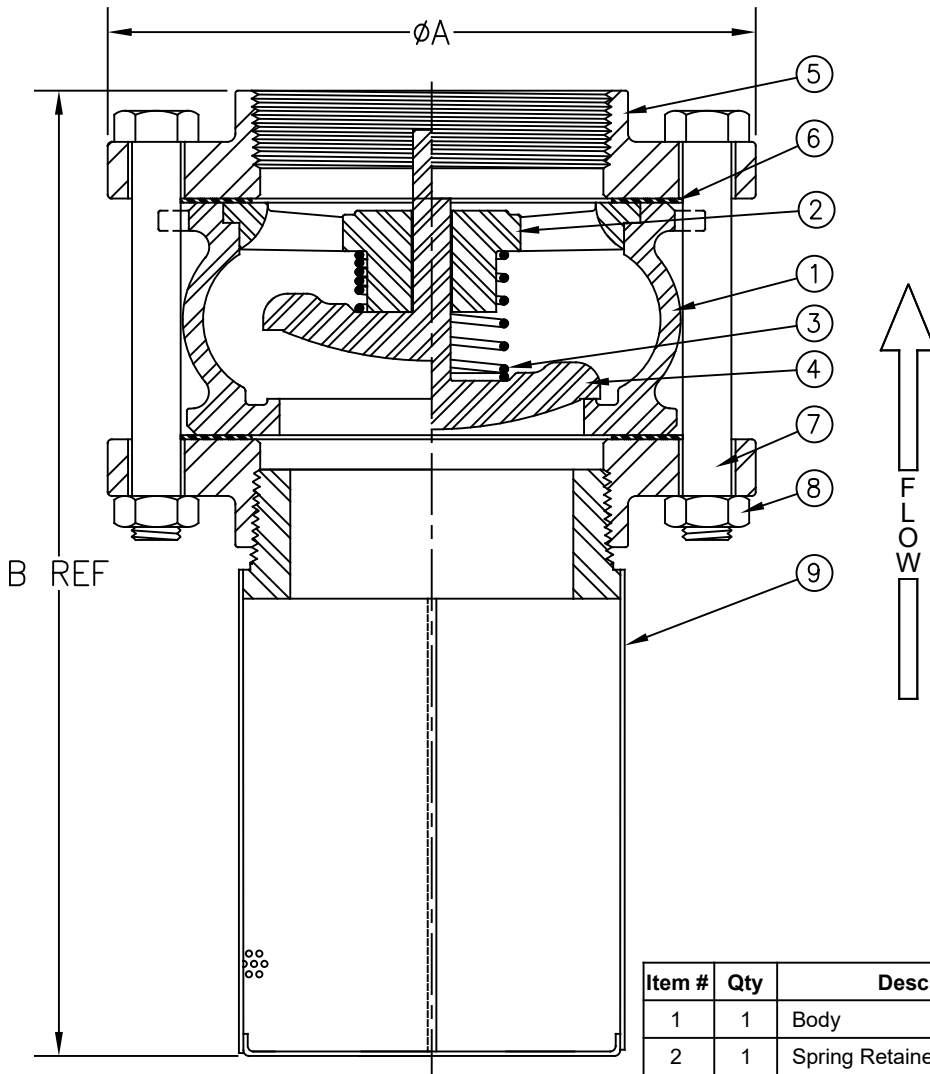

Open Area: 45%  
 Max Temp 400°F (200°C)  
 Max Pressure 300psi (21bar)

Item #	Qty	Description	Material	ASTM
1	1	Body	Stainless Steel	316
2	1	Spring Retainer	Stainless Steel	316
3	1	Spring	Stainless Steel	316
4	1	Seat Disc	Stainless Steel	316
5	2	End Flange	Stainless Steel	316
6	2	End Flange Gasket	Teflon	-----
7	AR	Hex Head Bolt	Stainless Steel	316
8	AR	Hex Nut	Stainless Steel	316
9	1	Screen*	Stainless Steel	316

## Dimensions (FNPT)

ANSI B1.20.1

Size		Part #	A		B (REF)		Weight	
inch	mm		inch	mm	inch	mm	lbs	kg
6	150	2430XTF	11	279	15-1/2	394	87	39
8	200	2431XTF	13-1/2	343	VARIES		151	68

Fromatic Corporation can accept no responsibility for possible errors in catalogues, brochures and other printed material. Fromatic Corporation reserves the right to alter its products without notices. This also applies to product already agreed. All trademarks in this material are property of the respective companies. All rights reserved. ©2022 Fromatic Corporation. The drawings & information on this drawing sheet are the sole & exclusive property of Fromatic Corporation. Any reproduction, distribution, display or use of these drawings or information in whole or in part without written authorization of Fromatic Corporation is strictly prohibited. [www>fromatic.com](http://www.fromatic.com)



October 15, 2004  
 Dwg No: S812XTF4 Rev C (8/22)

FLOMATIC CORPORATION  
 GLENS FALLS, N.Y. 12801  
 PHONE (518) 761-9797  
 FAX (518) 761-9798