

Foot Valve

Globe Style

Model 302BT



Sizes 14" Thru 24" / 350mm Thru 600mm

Flomatic Corporation

Material

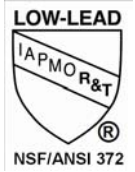
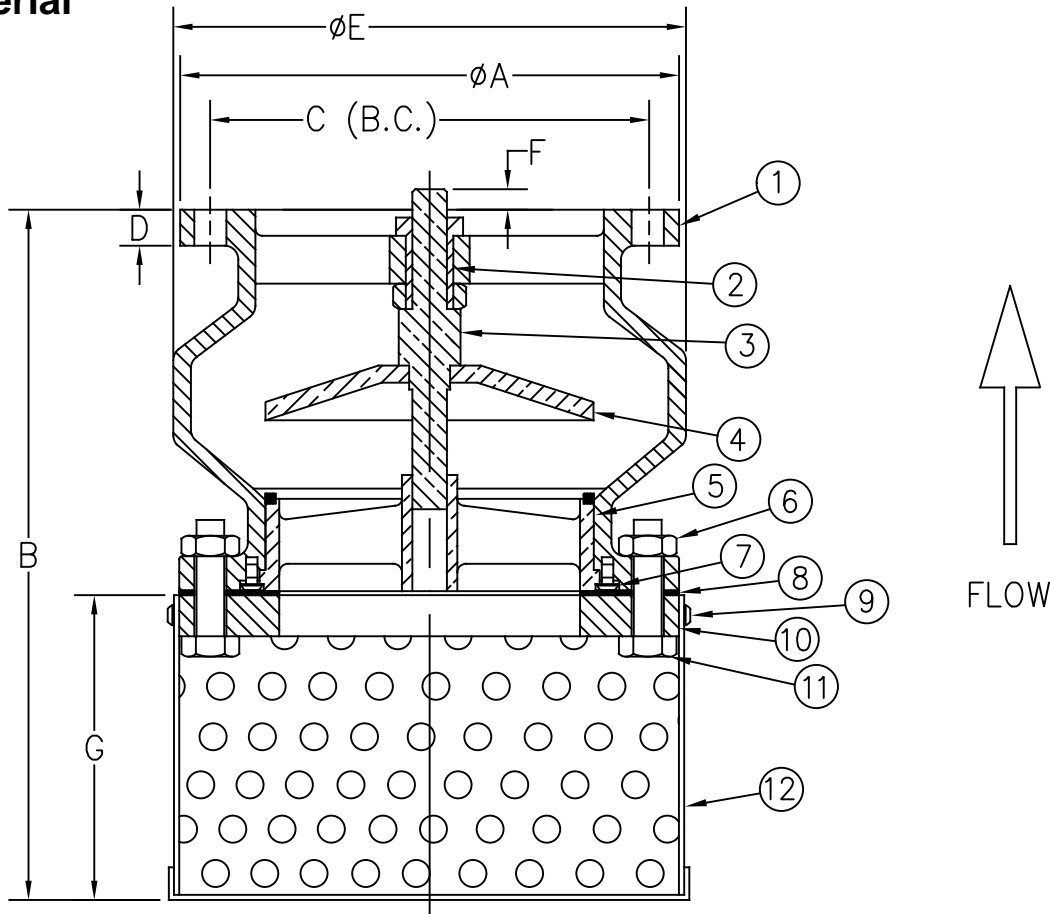

Open Area: 50-60%
 Max Temp 180°F (82°C)
 Max Pressure 150psi (10bar)

Item #	Qty	Description	Material	ASTM	Item #	Qty	Description	Material	ASTM
1	1	Body (epoxy coated)	Cast Iron	Class 35	7	3	Button Head Socket Screw	Stainless Steel	304
2	1	Bushing	Bronze	C93200	8	1	Gasket	Vellumoid	-----
3	1	Stem	Bronze	C93200	9	4	Button Head Socket Screw	Stainless Steel	304
4	1	Poppet	Federalloy	I-836-FL	10	1	Flange	Cast Iron	Class 35
5	1	Seat Ring	Federalloy	I-836-FL	11	AR	Hex Head Bolt	Zinc Plated Steel	-----
6	AR	Hex Nut	Zinc Plated Steel	-----	12	1	Strainer	Stainless Steel	304

AR=Amount Required

Dimensions (ANSI Class 125# Flange)

Size		Part #	A		B		C		D		E		F		G		Bolt Size	# of Bolts	Weight	
inch	mm		inch	mm	inch	mm	inch	mm	inch	mm	inch	mm	inch	mm	inch	mm			lbs	kg
14	350	5417BT	21	533	27-7/8	708	18-3/4	476	1-3/8	35	22	559	1-7/16	37	12	305	1	12	500	227
16	400	5418BT	23-1/2	597	33-3/4	857	21-1/4	540	1-7/16	37	25	635	2-1/4	57	16	406	1	16	650	295
18	450	5419BT	25	635	36-7/8	937	22-3/4	578	1-9/16	40	28	711	2-1/4	57	18	457	1-1/8	16	850	386
20	500	5420BT	27-1/2	699	40-3/4	1035	25	635	1-11/16	43	31	787	2-15/16	75	20	508	1-1/8	20	1050	476
24	600	5422BT	32	813	48-1/8	1222	29-1/2	749	1-7/8	48	37	940	3-5/8	92	24	610	1-1/4	20	1440	653

Flomatic Corporation can accept no responsibility for possible errors in catalogues, brochures and other printed material. Flomatic Corporation reserves the right to alter its products without notices. This also applies to product already agreed. All trademarks in this material are property of the respective companies. All right reserved. ©2011 Flomatic Corporation. The drawings & information on this drawing sheet are the sole & exclusive property of Flomatic Corporation. Any reproduction, distribution, display or use of these drawings or information in whole or in part without written authorization of Flomatic Corporation is strictly prohibited.



April 5, 1995
 Dwg No: S302bt-3 Rev: J (9/15)

FLOMATIC CORPORATION
 GLENS FALLS, N.Y. 12801
 PHONE (518) 761-9797
 FAX (518) 761-9798