

# Strainer

# Model 6P



Sizes 3/4" Thru 1-1/2" / 20mm Thru 40mm

## Materials

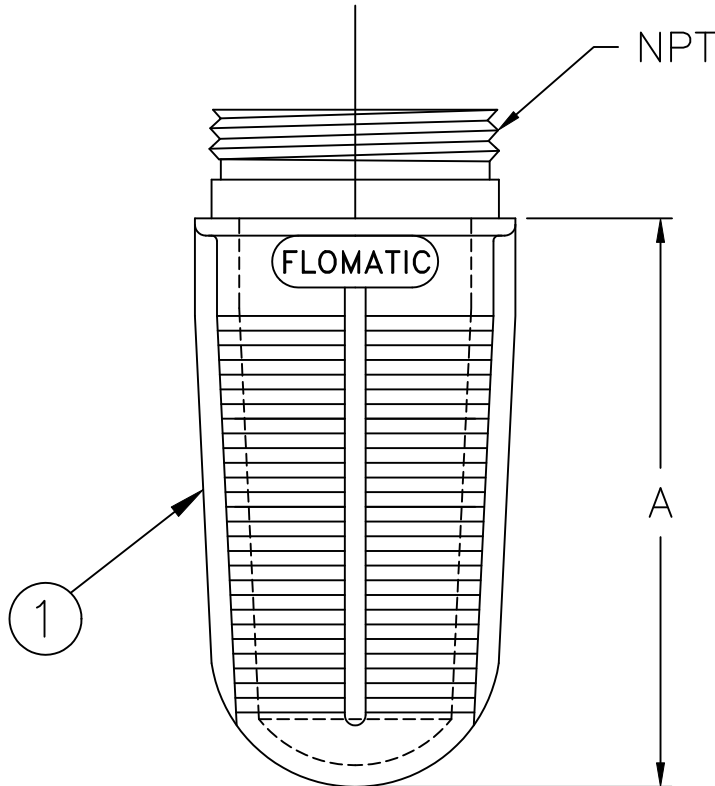

Open Area: 42%  
Max Temp 180°F (82°C)

Item #	Qty	Description	Material	ASTM
1	1	Screen	Polyethylene	-----

## Dimensions

Size (NPT)		Part #	A		Weight	
Inch	mm		Inch	mm	lbs	kg
3/4	20	4300P	2-1/4	57	.1	.05
1	25	4301P	2-1/2	64	.1	.05
1-1/4	32	4302P	2-5/8	67	.2	.09
1-1/2	40	4303P	3-9/16	90	.3	.14

Fromatic Corporation can accept no responsibility for possible errors in catalogues, brochures and other printed material. Fromatic Corporation reserves the right to alter its products without notices. This also applies to product already agreed. All trademarks in this material are property of the respective companies. All right reserved. ©2011 Fromatic Corporation. The drawings & information on this drawing sheet are the sole & exclusive property of Fromatic Corporation. Any reproduction, distribution, display or use of these drawings or information in whole or in part without written authorization of Fromatic Corporation is strictly prohibited.



January 16, 1998  
Dwg No: S4300-3P Rev B (3/13)

FLOMATIC CORPORATION  
GLENS FALLS, N.Y. 12801  
PHONE (518) 761-9797  
FAX (518) 761-9798