

Strainer

Model 46T



Flomatic Corporation

Sizes 2" Thru 4" / 50mm Thru 100mm



Material

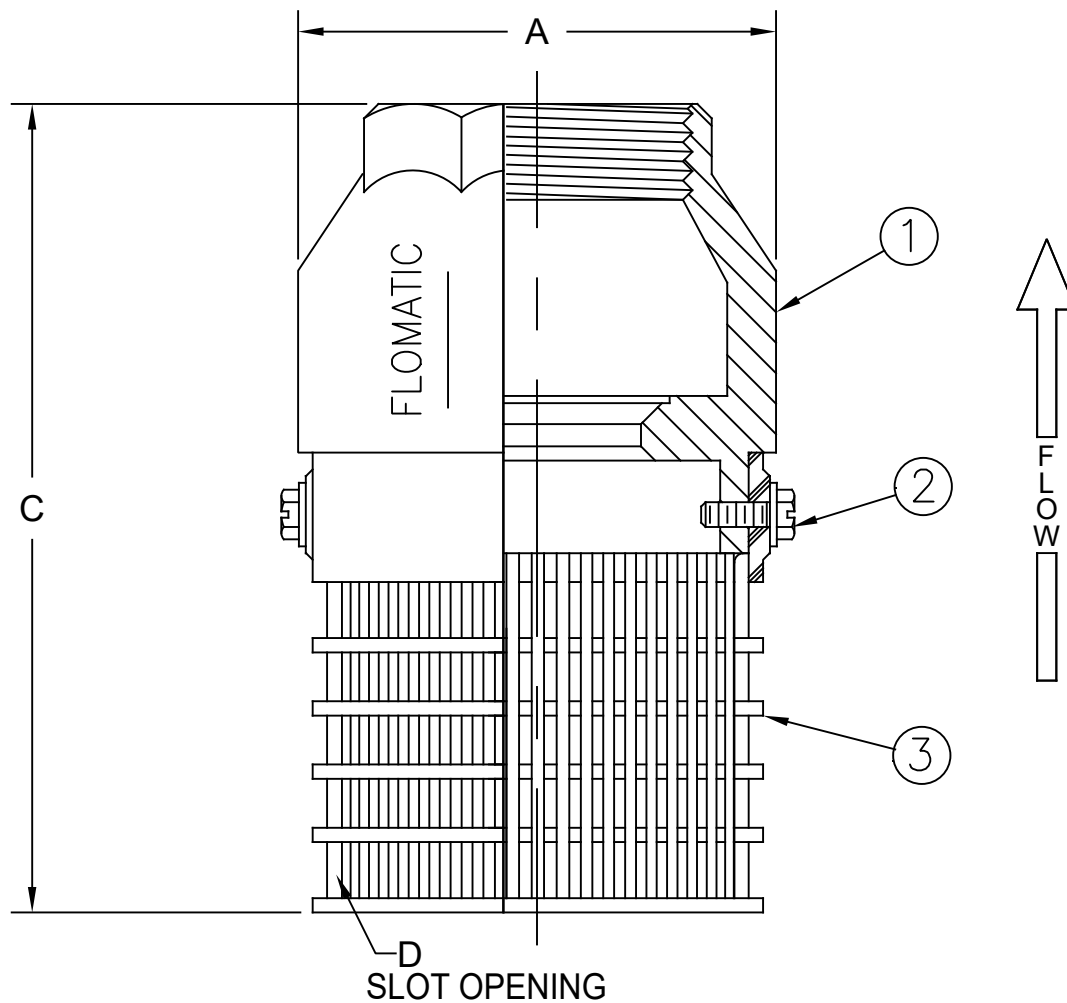

Open Area: 35-50%
 Max Temp 180°F (82°C)
 Max Pressure 250psi (18bar)

Item #	Qty	Description	Material	ASTM
1	1	Body	Cast Iron	A126
2	2	Type F Screw	Plated Steel	-----
3	1	Screen	Polyethylene	-----

Dimensions

ANSI B1.20.1

Size		Part #	A		B		C		D		Weight	
inch	mm		inch	mm	inch	mm	inch	mm	inch	mm	lbs	kg
2	50	4364	3-13/32	86	2-19/32	66	6-1/16	154	.10 x .35	2 x 9	2.5	1.1
2-1/2	65	4365	4-11/32	119	2-3/4	70	6-15/16	176	.12 x .47	3 x 12	4	1.8
3	80	4366	5-1/4	133	3-3/4	96	9-9/64	232	.14 x .60	4 x 15	8.2	3.7
4	100	4367	6-3/8	162	4-21/32	118	11-13/32	290	.18 x .73	5 x 19	14	6.4

Flomatic Corporation can accept no responsibility for possible errors in catalogues, brochures and other printed material. Flomatic Corporation reserves the right to alter its products without notices. This also applies to product already agreed. All trademarks in this material are property of the respective companies. All rights reserved. ©2024 Flomatic Corporation. The drawings & information on this drawing sheet are the sole & exclusive property of Flomatic Corporation. Any reproduction, distribution, display or use of these drawings or information in whole or in part without written authorization of Flomatic Corporation is strictly prohibited. www.flomatic.com



January 20, 1998
 Dwg No: S4364-7 Rev: D (1/24)

FLOMATIC CORPORATION
 GLENS FALLS, N.Y. 12801
 PHONE (518) 761-9797
 FAX (518) 761-9798