

# Strainer

# Model 6SE



Flomatic Corporation

Sizes 2-1/2" Thru 4" / 65 mm Thru 100 mm

## Material

Enviro Check®

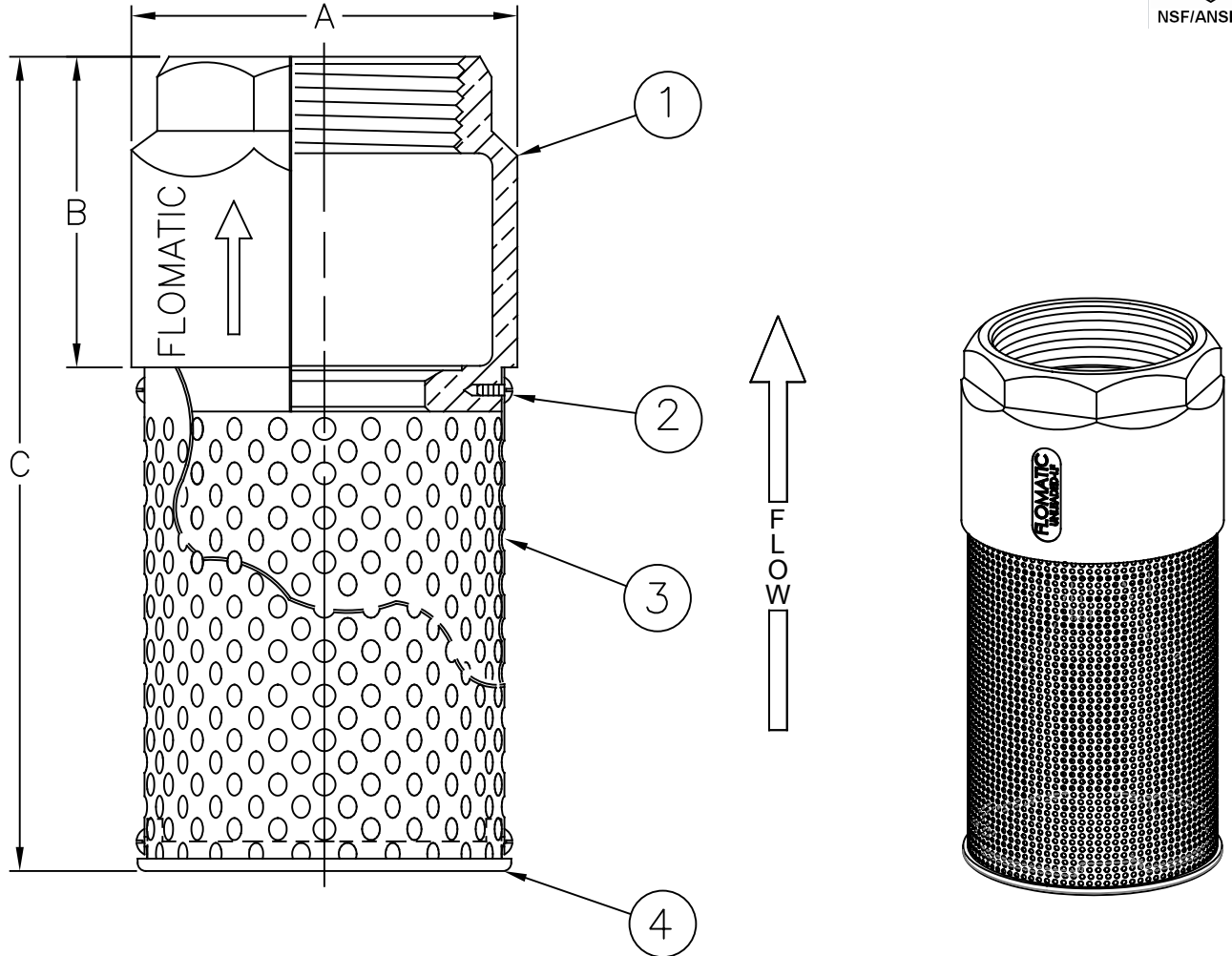

Open Area: 35-50%  
 Max Temp 180°F (82°C)  
 Max Pressure 250psi (18bar)

Item #	Qty	Description	Material	ASTM
1	1	Body	Unleaded Bronze	C89833
2	1	Screw*	Stainless Steel	316
3	1	Screen	Stainless Steel	304
4	1	Cap	Unleaded Bronze	C89833

\* 3" & 4" Screw is 18-8SS or 302SS

## Dimensions (FNPT)

ANSI B1.20.1

Size		Part #	A		B		C		Weight	
inch	mm		inch	mm	inch	mm	inch	mm	lbs	kg
2-1/2	65	4305E	3-21/32	93	2-11/16	68	7-13/16	198	3	1.4
3	80	4306E	4-9/16	116	3-13/32	97	9-9/16	243	7.2	3.3
4	100	4307E	6-1/8	156	4-1/4	108	12-13/32	315	14	6.4

Flomatic Corporation can accept no responsibility for possible errors in catalogues, brochures and other printed material. Flomatic Corporation reserves the right to alter its products without notices. This also applies to product already agreed. All trademarks in this material are property of the respective companies. All rights reserved. ©2024 Flomatic Corporation. The drawings & information on this drawing sheet are the sole & exclusive property of Flomatic Corporation. Any reproduction, distribution, display or use of these drawings or information in whole or in part without written authorization of Flomatic Corporation is strictly prohibited. [www.flomatic.com](http://www.flomatic.com)



January 20, 1998  
 Dwg No: S4305E-7 Rev: G (1/24)

FLOMATIC CORPORATION  
 GLENS FALLS, N.Y. 12801  
 PHONE (518) 761-9797  
 FAX (518) 761-9798